

INDUSTRIAL CHILLER

Operation Instruction



目 录

1. 前言/FOREWORD	1
2. 机器说明/MACHINE INSTRUCTION	1
2.1. 机型定义 MODEL DEFINITION	2
2.2. 特点/FEATURES	3
2.3. 工业冷水机原理图 INDUSTRIAL CHILLER SCHEMATIC DIAGRAM	5
2.4. 冷水机外型图 INDUSTRIAL CHILLER OUTLINE DRAWING	6
3. 机器参数及尺寸/MACHINE PARAMETERS AND DIMENSIONS	7
4. 安全规则/SAFETY REGULATIONS	11
5. 安装与使用/ INSTALLATION AND OPERATION	12
5.1. 安装/INSTALLATION	12
5.2. 操作/OPERATE	14
5.3. 控制面板操作说明 CONTROL PANEL OPERATING INSTRUCTIONS	17
6. 维修与保养 REPAIR AND MAINTENANCE	22
6.1. 维修 REPAIR	22
6.2. 保养 MAINTENANCE	23
7. 故障与排除 TROUBLE SHOOTING	25
8. 电气部分/ ELECTRICAL PARTS	27
9. 部件名称/PARTS LIST	39
10. 维修保养记录表 MAINTENANCE RECORD SHEET	43
10.1. 机器资料 MACHINE INFORMATION	43
10.2. 安装检查 INSTALLATION CHECK	43
10.3. 电气检查 ELECTRICAL CHECK	43
10.4. 日检 DAILY CHECK	44
10.5. 周检 WEEKLY CHECK	47
10.6. 月检 MONTH CHECK	48
10.7. 季检 SEASON CHECK	49

1. 前言/FOREWORD



在使用本机前应该仔细阅读使用手册，以便正确使用机器，避免因操作不当造成机器损坏。

Please study this manual carefully before using the machine.

2. 机器说明/MACHINE INSTRUCTION

HC 系列工业冷水机主要适用于塑胶工业,它可以精确的控制塑胶成型模具温度以缩短成型周期,加速产品定型;也适用于冷却各种液压机以稳定的保持其工作油温;另外也适用于电镀业/食品业/电子业及漂染业等其他行业。该系列冷水机在结构上它区分风冷式及水冷式两种,能精确又稳定的提供温度在 5~30℃ 冰水(温差不超过 $\pm 1^{\circ}\text{C}$), 冷却能力 6,800 至 120,000kcal/hr。

Industrial chillers is mainly applied to the plastic industry, Industrial chillers can accurately control the temperature of the plastic mold to shorten the molding cycle, accelerate product stereotypes; Suitable for cooling a variety of hydraulic press to maintain a stable working oil temperature; Also applies to the electroplating industry / food industry / electronics industry and dyeing and finishing industry and other industries. The series of chillers are divided into air-cooled and water-cooled two types, can provide accurate and stable temperature of 5 ~ 30 °C ice water (the temperature does not exceed $\pm 1^{\circ}\text{C}$), cooling capacity 6,800 to 120,000 kcal / hr.

2.1. 机型定义 MODEL DEFINITION

HC- AAA - BBB - CCC

HC 华热工业冷水机 HUARE Industrial Chiller

AAA 压缩机 HP 数 Compressor HP number

BBB ACI=风冷盘管 Air cooling condenser coil evaporator

SACI=风冷壳管 Air cooling condenser shell evaporator

PACI=风冷板换 Air cooling condenser board evaporator

WCI=水冷盘管 Water cooling condenser coil evaporator

SWCI=水冷壳管 Water cooling condenser shell evaporator

PWCI=水冷板换 Water cooling condenser board evaporator

CCC D=双机头 Double head

T=三机头 Three head

L=双层式水冷机型 Two - layer water cooled models



盘管蒸发器

Coil evaporator



壳管蒸发器

Shell evaporator



板换蒸发器

Board evaporator

2.2. 特点/FEATURES

- 1) 采用欧美进口高质全新设计压缩机及名牌水泵、风机，省电耐用；
- 2) 独有全新设计之散热器，换热效能佳；
- 3) 备有不锈钢开放式水箱，清洗修护方便快捷；
- 4) 配备微电脑温度控制器，精确控温 $\pm 1^{\circ}\text{C}$ ；
- 5) 本机标准配置自动补水功能，逆缺相保护，电流过载保护，高低压保护及多项电子时间延迟等安全保护与功能，当发生故障时，随即发出警报。
- 6) 双机头机型压缩机累计时间轮值开机，有效均衡运行时间，提升机器寿命。

可选配： R407C 环保冷媒机型、多口分流管、高扬程泵浦、外部水箱等
HLINK 联网功能可选配；

- 1) Using European and the United States imports of high-quality design compressor and brand-name pumps, fans, Power saving and durable.
- 2) Unique new design of the heat exchanger, heat transfer efficiency.
- 3) Equipped with stainless steel open tank, cleaning repair convenient and quick.
- 4) Equipped with microcomputer temperature controller, precise temperature control $\pm 1^{\circ}\text{C}$.
- 5) Standard with automatically water function, reverse phase protection, current overload protection, high and low pressure protection and a number of electronic time delay and other

security protection and function, when a failure occurs immediately issued an alarm.

6) In double head models machine the compressor according to the cumulative time to run as a host rotation, effective balance the two compressors running time, improve machine life.

optional : R407C environmentally friendly refrigerant, multi-tube water row, high-lift pump, external water tanks and other requirements can be optional.

HLINK networking function can be optional

注意事项：

机器标准电压规格为：3 φ 380V 50Hz。

机型的选择取决于注塑重量和所需制冷量。

客户如需定制特殊规格，请与本公司联系确认。

产品规格若有变更，恕不另行通知。

Note :

The standard voltage is 3 φ ,380V, 50Hz.

Refer to the shot weight and cooling capacity to select the machine.

Have any special needs, please contact us.

We reserve right to change specifications without prior notice.

2.3. 工业冷水机原理图 INDUSTRIAL CHILLER SCHEMATIC DIAGRAM

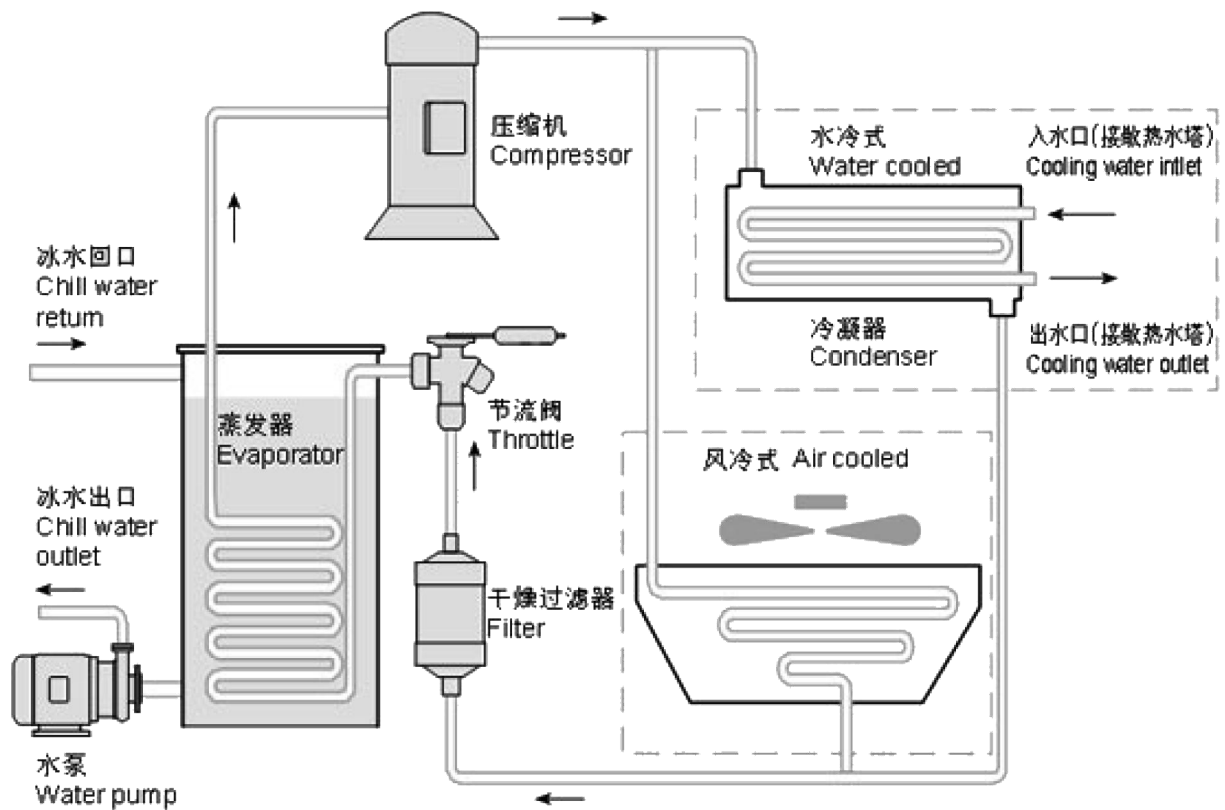

2.4. 冷水机外型图 INDUSTRIAL CHILLER OUTLINE DRAWING

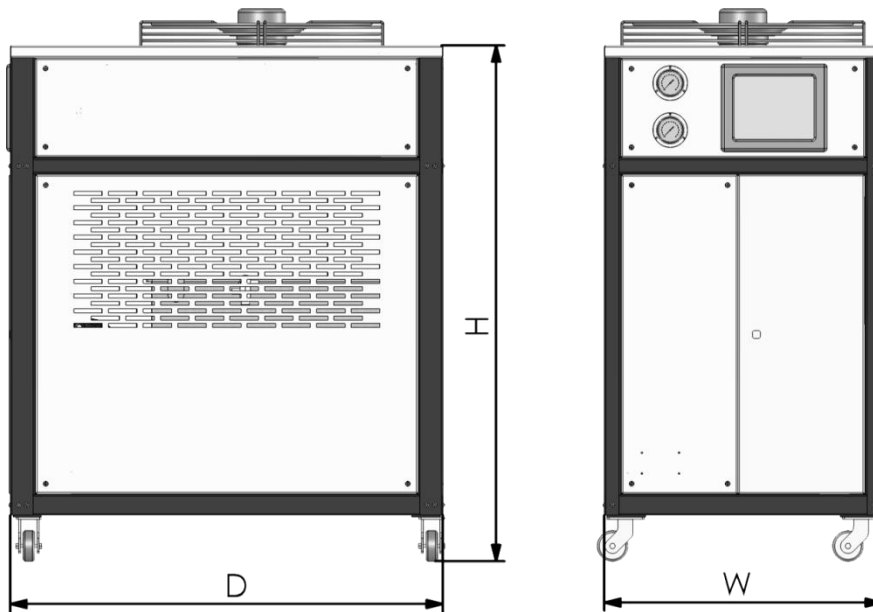

HC- XX ACI

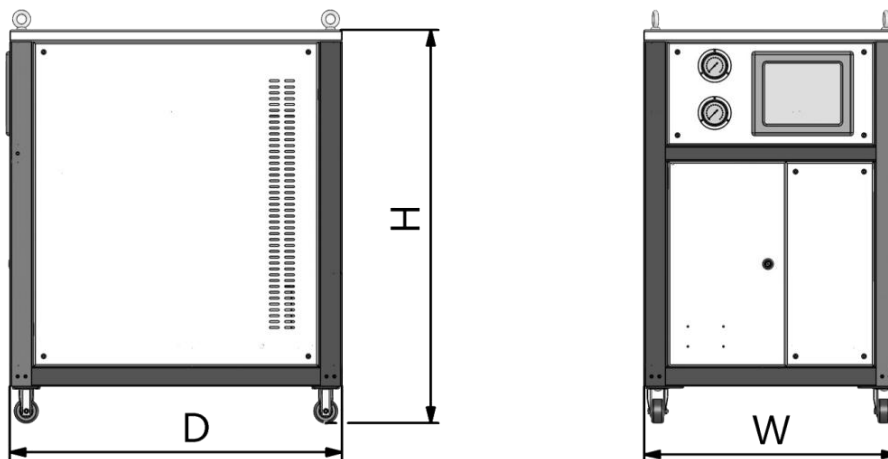

HC- XX WCI

3. 机器参数及尺寸/MACHINE PARAMETERS AND DIMENSIONS

风冷箱式工业冷水机 Air Cooled Cased Industrial Chiller

型号	Type			Unit	HC-03ACI	HC-05ACI	HC-08ACI	HC-10ACI	HC-12SACI	HC-15SACI	
制冷量	Cooling capacity			kW	8	14	22	30	37	42	
				kcal/h	6800	12040	19000	25200	32000	37000	
压缩机	Compressor	类型	type	全封闭涡旋式 All-close scroll							
		功率	power	kW	2.5	4.4	7	9	10.5	13.4	
冷冻媒体	Refrigerant	类型	type	R22(R407C)							
蒸发器	Evaporator	类型	type	水箱沉浸式 Water tank immersion					壳管蒸发器 Shell evaporator		
风冷 冷凝器	Air cooled condenser	类型	type	翅片式冷凝器 Finned condenser							
		风机 功率	fan power	kW	0.25	0.6	0.25x2	0.45x2	0.45x2	0.6x2	
水泵	Pump	功率	power	kW	0.75	0.75	1.5	1.5	1.5	3	
		流量	flow	L/min	83	83	208	208	208	330	
水箱容量	Water tank capacity			Liter	100	100	160	200	160	160	
冷冻水 接管口径	Frozen water inlet and outlet			Inch	1	1	1.5	1.5	1.5	2	
重量	Weight			kg	190	220	310	390	420	520	
外形尺寸	Dimensions										
H				mm	1250	1250	1450	1500	1500	1700	
W				mm	680	680	700	800	900	960	
D				mm	1060	1060	1360	1470	1470	1580	

型号	Type			Unit	HC-20SACI-D	HC-25SACI-D	HC-30SACI-D	HC-40SACI-D	HC-50SACI-D
制冷量	Cooling capacity			kW	52	62	86	104	125
				kcal/h	45000	54000	74000	90000	108000
压缩机	Compressor	类型	type	全封闭涡旋式 All-close scroll					
		功率	power	kW	9x2	10.5x2	13.4x2	17.8x2	20x2
冷冻媒体	Refrigerant	类型	type	R22(R407C)					
蒸发器	Evaporator	类型	type	壳管式蒸发器 Shell evaporator					
风冷 冷凝器	Air cooled condenser	类型	type	翅片式冷凝器 Finned condenser					
		风机 功率	fan power	kW	0.45x4	0.6x4	0.6x4	0.6x6	0.7x6
水泵	Pump	功率	power	kW	3	3	4	5.5	5.5
		流量	flow	L/min	330	330	500	660	660
水箱容量	Water tank capacity			Liter	250	250	320	450	450
冷冻水 接管口径	Frozen water inlet and outlet			Inch	2	2	2.5	2.5	3
重量	Weight			kg	800	810	860	1000	1120
外形尺寸	Dimensions								
H				mm	1800	1800	1900	1940	1940
W				mm	1600	1600	1900	1950	1950
D				mm	1480	1480	2400	2540	2840

水冷箱式工业冷水机 Water Cooled Cased Industrial Chiller

型号	Type			Unit	HC-03WCI	HC-05WCI	HC-08WCI	HC-10WCI	HC-12SWCI	HC-15SWCI	
制冷量	Cooling capacity			kW	9	15	25	32	40	48	
				kcal/h	7580	13500	21150	28000	34000	41000	
压缩机	Compressor	类型	type	全封闭涡旋式 All-close scroll							
		功率	power	kW	2.5	4.4	7	9	10.5	13.4	
冷冻媒体	Refrigerant	类型	type	R22(R407C)							
蒸发器	Evaporator	类型	type	水箱沉浸式 Water tank immersion					壳管蒸发器 Shell evaporator		
水冷 冷凝器	Water cooled condenser	类型	type	壳管式冷凝器 Shell condenser							
		冷却水量	Water flow	L/min	≥36	≥60	≥100	≥135	≥160	≥200	
水泵	Pump	功率	power	kW	0.75	0.75	1.5	1.5	1.5	3	
		流量	flow	L/min	83	83	208	208	208	330	
水箱容量	Water tank capacity			Liter	60	60	120	130	150	180	
冷却水 接管口径	Chill water inlet and outlet			Inch	1	1	1.5	1.5	1.5	2	
冷冻水 接管口径	Frozen water inlet and outlet			Inch	1	1	1.5	1.5	1.5	2	
重量	Weight			kg	165	180	260	340	380	450	
外形尺寸	Dimensions										
H				mm	1000	1000	1200	1200	1200	1360	
W				mm	650	650	800	800	800	1000	
D				mm	850	850	1050	1200	1300	1550	

型号	Type			Unit	HC-20SWCI-D	HC-25SWCI-D	HC-30SWCI-D	HC-40SWCI-D	HC-50SWCI-D
制冷量	Cooling capacity			kW	58	70	95	115	140
				kcal/h	50000	60000	82000	100000	120000
压缩机	Compressor	类型	type	全封闭涡旋式 All-close scroll					
		功率	power	kW	9x2	10.5x2	13.4x2	17.8x2	20x2
冷冻媒体	Refrigerant	类型	type	R22(R407C)					
蒸发器	Evaporator	类型	type	壳管式蒸发器 Shell evaporator					
水冷冷凝器	Water cooled condenser	类型	type	壳管式冷凝器 Shell condenser					
		冷却水量	Water flow	L/min	≥135x2	≥160x2	≥200x2	≥240x2	≥300x2
水泵	Pump	功率	power	kW	3	3	4	5.5	5.5
		流量	flow	L/min	330	330	500	660	660
水箱容量	Water tank capacity			Liter	250	250	310	380	470
冷却水接管口径	Chilled water inlet and outlet			Inch	1.5x2	1.5x2	2x2	2.5x2	2.5x2
冷冻水接管口径	Frozen water inlet and outlet			Inch	2	2	2.5	2.5	3
重量	Weight			kg	740	750	800	920	1000
外形尺寸	Dimensions								
H				mm	1360	1360	1380	1470	1470
W				mm	1200	1200	1250	1400	1400
D				mm	1800	1800	1900	2050	2050

4. 安全规则/SAFETY REGULATIONS

注意/Note :

电器安装应由专业的电工来安装，在机器维修保养时，应先关闭主电源开关和自动运行开关。

All the servicing and maintenance work should be done by the servicing engineer and the circuit should be checked by the electricity engineer.

操作机器时应注意如下标记：

You can find the following labels stuck on the machine



注意! 说明书!

此标记表示按照说明书操作

CAUTION !

This label means you should study this manual carefully before using the machine.

AC 380V 3 ϕ

所需电源! 交流三相 380V

Three phase supply at 380V



危险! 高压危险!

此标记贴在控制箱外壳上

Warning !

High voltage

Don't touch



注意!

机器运转之前请先接地

Caution!

Keep ground wire connected

Installation

- 1) Keep the chiller in an upright position during transport and do not tilt during transport and handling. The tilting of the chiller may easily affect the internal suspension of the compressor.
- 2) The chiller must be carried by a forklift.
- 3) On receipt of the mold temperature controller, it must be inspected for damage. Many unexpected accidents may occur during transport although all machines are checked before dispatch
- 4) Place the machine at a proper position on the ground, connect the power source in accordance with the wiring diagram.
- 5) The distance between the machine and the mold is at most 5m with well ventilated environment. The machine couldn't cling to the wall or other machine because lateral panels of the housing has scavenge-air ports. If the scavenge-air ports are blocked, the machine will not work normally.
- 6) Don't install the machine at the following position
 - ✧ Out-door
 - ✧ In a dust、 moisture atmosphere.
 - ✧ In a direct fired unit atmosphere.
 - ✧ In a inflammable gas atmosphere.
 - ✧ In a corrosive gas atmosphere

联接管口分布图 Connection nozzle layout

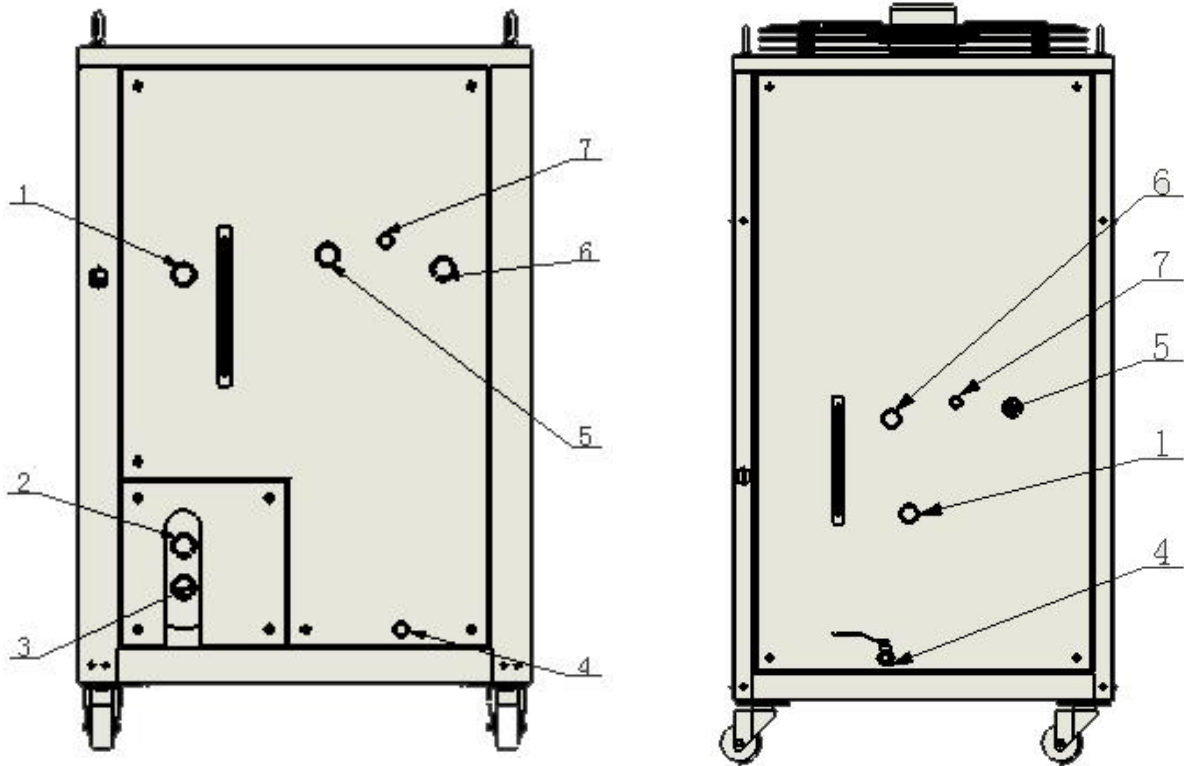

HC-XX WCI

HC- XX ACI

No.	管口名称 Spout name	备注 Remarks
1	冷冻水出口 Chilled water outlet	
2	冷却水出口 Cooling water outlet	仅限水冷机型 Water-cooled models only
3	冷却水进口 Cooling water inlet	仅限水冷机型 Water-cooled models only
4	排污口 Sewage outfall	
5	冷冻水入口 Chilled water inlet	
6	溢水口 Overflow	
7	加水口 Add water	

Operate

Pipe connection confirmation

- 1) Make sure that all piping is connected and tightened by label.
(Including: water intake, overflow, chilled water imports, chilled water exports, sewage outfall, and water cooling models of cooling water imports, cooling water exports).
- 2) Make sure that the size of the inlet and outlet pipes is not less than the size of the machine.
- 3) The inside of the water intake is equipped with a float valve to achieve automatic replenishment and automatic closing of the water. Please note that the ball valve at the outer end of the water intake must be in the open state when the machine is working

Ready before operation

- 1) Confirm the power connection.
- 2) The supplied supply voltage and frequency must be checked with the machine power supply specifications.
- 3) The circuit of the machine shall not be altered without the consent of the Company. If the circuit is changed, causing damage to the machine, Our company does not assume any responsibility.
- 4) When the power is turned on, the phase sequence indicator on the control board will prompt the power supply wiring phase sequence status. When the phase sequence indicator prompts reverse, turn off the power and disconnect the power supply into any two.

Panel key layout instructions



Common interface

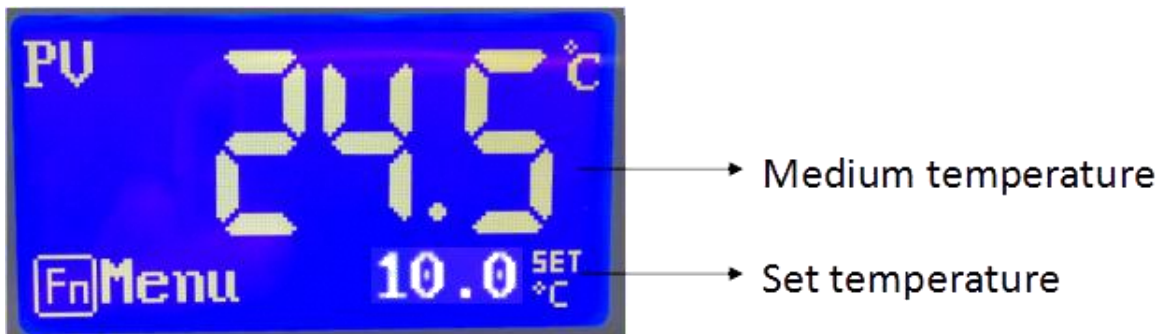

Common operation

Quickly change the set temperature

If the user parameter [lock temperature] is set to "no", the main interface can be directly modified to set the temperature.

The operation is as follows:



Note: You can also modify the set temperature in the user parameter.

User menu

Press <function> in the main interface to enter the user menu, the user menu parameters as follows

ITEM	Parameter item	Parameter function	Remarks
1	User settings	Set the user commonly used parameters	
2	Unit status	Show the current running status of the unit	The current value is not displayed when the current module is not used
3	Historical failure	You can check for the last 10 failures	Press <OK> key 2s to clear the history fault.
4	Equipment usage	Show compressor total running time	
5	Version Information	Query the currently used software version	

User settings parameter table

User-defined parameters and parameters are as follows

No	Parameter item	Factory default	Predetermined area	Remarks
1	Lock the temperature	No	Yes/No	Yes : You can quickly modify the set temperature in the main interface. No :You can't quickly modify the set temperature in the main interface
2	Set temperature	12.0°C	【Set lower limit】 ~ 【Set upper limit】	The setting range is limited by the factory setting of "set temperature upper limit" and "set temperature lower limit". °C display
3	Set temperature	12.0°C	【Set lower limit】 ~ 【Set upper limit】	The setting range is limited by the factory setting of "set temperature upper limit" and "set temperature lower limit". °F display
4	Temperature unit	°C	°C OR °F	
5	Adjust the contrast	32	20~44	Adjust the LCD contrast
6	Start and stop mode	Local	Local/ Local+Remote/ Remote	Local : Only local control start and stop units Local+Remote :Both local and remote can control start and stop Remote : Only remote control start and stop units
7	Shut down the backlight time	0 Min	0~255 Min	Set to 0: The backlight is always on Set to other: To reach the set value within the time the controller is not operating, the controller backlight off.
8	Multilingual	Chinese	Chinese ~English	Chinese : Display Chinese interface English : Display English interface
9	Compressor use settings	2 compressors	1 # compressor 2 # compressor 2 compressors	Select the compressor that is allowed to turn on. When one of the presses is selected, the other press does not work and the control logic is the same as the single compressor. This parameter is not displayed for single compressors.

6. 维修与保养 REPAIR AND MAINTENANCE



机器维修或保养前必须关闭电源。

The power must be turned off before the machine is repaired or maintained.

6.1. 维修 Repair

所有的维修必须由专业人员来完成，避免造成人身伤害及损坏机器。

All repairs must be done by professionals to avoid personal injury and damage to the machine.

Maintenance

Daily check

- Check the appearance of the unit clean
- Check the function of the machine switch
- Check all cables of the machine

Weekly check

- Check fixed internal components, and the surrounding ventilation
- Check electrical components joints loose
- Check the water level in the tank
- Check for leaks in the water line
- Check and clean Y-strainer
- Check motor overload function and reverse phase protection function

Month check

- Detection of temperature probe and temperature control is normal
- Measure and record high and low pressure and temperature control temperature is normal.
- Check the compressor for any abnormal sound and abnormal vibration.
- Check the frozen water, cooling water quality is normal, when the water quality becomes dirty, deterioration, please change the water source

Season check

- Check the level of pressure switch, thermostat.
- Cleaning cooling tower (water-cooled cumulative run three months to clean once).
- Clean the condenser (cumulative run six months to clean once).
- Clean up the dust inside the machine (cleaned once every six months)

ITEM	MALFUNCTION	TROUBLE SHOOTING
1	Reverse phase alarm	After disconnecting the power supply, exchange any two-phase and then reconnect it
2	Frozen water pump does not water	Correct pump motor rotation direction Outlet pipe exhaust Impeller clogged, cleaning impeller
3	Chilled water pump is running low folw	Check clean chilled water pipe Outlet pipe exhaust Impeller clogged, cleaned or replaced impeller
4	Compressor does not start or stop immediately after starting	Check the external power supply meets the requirements of the machine; Improper adjustment of the temperature controller, re-adjust the temperature controller; Cooling water is not open, high pressure overload, open the cooling water; Overload protector does not start after reset button, RESET reset; Overload protection, mandatory 60 seconds before the time, wait for the boot;
5	High pressure during operation is too high	Cooling water flow is too small, water temperature too high, cooling water pipes maybe blocked, check and clean Condenser have too much dirt, cleaning the condenser surface and piping Condenser direct sunlight, shade treatment; Too much refrigerant, high pressure, excessive refrigerant emissions The condenser has a large number of non-condensable gases, the discharge of non-condensable gases Expansion valve opening degree is too small, adjust the expansion valve opening degree
6	Low pressure during operation is too low	Leakage refrigerant, leak check, unit maintenance; Refrigerant refrigerant insufficiency, additional refrigerant; Dry filter clogged, washable or replace the dry filter Chilled water contains air to participate in the cycle, the air chilled water discharge Evaporation surface fouling, cleaning the evaporator surface Set the chilled water temperature is too low, adjust the set temperature
7	Return air pipe and compressor housing frost	Expansion valve opening degree is too large, adjust the expansion valve opening degree Excess refrigerant, discharge excess refrigerant Heat load is too small, increase heat load Chilled water set temperature is too low cause the evaporator surface icing, adjust the set temperature

VII. Solutions for faults

7.1 System faults

Name	Description	Test Conditions	Actions	Reasons	Troubleshooting
1#Comp .P high	High pressure of compressor1	Test when the compressor button has pressed	Stop compressor1 only without affect other equipments to work. [Note1]	<ol style="list-style-type: none"> Poor heat dissipation High pressure switch is damaged High pressure signal line fault “High pressure” setting is not right High pressure rate setting is not correct 	<ol style="list-style-type: none"> See Footnote (1). Replace the high pressure switch Check if the signal line is virtual open or not Check the settings Check high pressure switch and adjust the setting, see Footnote (3) and Footnote (5)
1#Comp .P low	Low pressure of compressor1	<p>If the [LP check delay] is 0, test when the compressor button has pressed;</p> <p>If the [LP check delay] is not 0, then compressor1 runs the test.</p>		<ol style="list-style-type: none"> The dry filter got clogged. Expansion valve failure The low pressure setting is not right. Insufficient refrigerant. Low pressure switch signal failure. Low pressure switch is damaged Comp LoPress” setting is not right 	<ol style="list-style-type: none"> Replace new filters. Adjust or replace expansion valve. Check low pressure switch and adjust the setting and see Footnote (3) and Footnote (5) Charge refrigerant, see Footnote (2). Check if the signal line is virtual open or not Replace the low pressure switch Check the settings
1#Comp overload	The compressor1 overload	Compressor1 runs the test.		<p>Immediate Reason:</p> <ol style="list-style-type: none"> The setting of thermal overload relay is too low. Thermal overload relay signal failure Thermal overload relay damaged ” Comp Overload” setting is not right <p>Indirect Reason:</p> <ol style="list-style-type: none"> Poor heat dissipation 	<ol style="list-style-type: none"> Start unit to see if the compressor current is normal, if it is normal, adjusting the current setting appropriately. Check if the signal line is virtual open or not Replace the thermal overload relay Check the settings See Footnote (1).
1#Comp .I high	The current of compressor1 is too high			Check if the rated current of compressor1 is input is reasonable.	
1#Comp .I low	The current of compressor1 is too low			Check if the measure tool of the compressor1 current is connect.	
1#T.Vent high	The vent temperature of compressor1 is too high		Check if the input is consistent with the switch setting.		
2#Comp .P high	High pressure of compressor2	Test when the compressor button has pressed	Stop compressor2	See “1#Comp.P high”	See “1#Comp.P high”

2#Comp.P low	Low pressure of compressor2	If the [LP check delay] is 0, test when the compressor button has pressed; If the [LP check delay] is not 0, then compressor2 runs the test.	only without affect other equipments to work. [Note2]	See “1#Comp.P low”	See “1#Comp.P low”
2#Comp overload	The compressor2 overload	Compressor2 runs the test.		See “1#Comp. overload”	See “1#Comp. overload”
2#Comp.I high	The current of compressor2 is too high				Check if the rated current of compressor2 is input is reasonable.
2#Comp.I low	The current of compressor2 is too low				Check if the measure tool of the compressor2 current is connect.
2#T.Vent high	The vent temperature of compressor2 is too high				Check if the input is consistent with the switch setting.
Temp.low AL	The liquid temperature is too low	Test after cold pump starts	Stop the compressor and delay to stop the cool pump, and do not stop the cold pump.	1. The water temperature setting value is over low 2. “T.low protect” valve setting is so low 3. The setting temperature value is over low 4. System out probe failure	1.Stop chilling, reset it until the temperature is going up 2. Check the settings 3.Add the setting temperature value 4. Replace the probe
T.high warn	The liquid temperature is higher than the warn value.		Alarm only without affect other equipments to work.	1. The water temperature setting value is over high 2. “T.high warn” valve setting is so low 3. The heater is keep running(Cold-hot dual-purpose machine has this function) 4.The chiller is not running or low refrigeration efficiency 5. System out probe failure	1. Replace the new water , reset it until the temperature is going down. 2. Check the settings 3. Check if the heater is keep running. 4. Check if the chiller is well in working, or if the refrigeration efficiency is satisfy, or if the water temperature is abnormally high 5. Replace the probe
Temp.high AL	The liquid temperature is too high		Stop the compressor and delay to stop the cool	See “T.high warn”	See “T.high warn”

			pump, and do not stop the cold pump.		
Anti-freeze.AL	Antifreeze alarm	Power on to test	Stop all the compressor and cool pump, and do not stop the cold pump.		Check if the antifreeze input is consistent with the switch setting.
Probe break	The liquid temperature sensor is break			1.The probe break or damaged	Check if the temperature probe is in proper contact.
Probe short	The liquid temperature sensor is short			1.The probe short or damaged	
cool fan overload [Note3]	The cool pump or fan overload	Test after Cool pump starts	Stop compressor and cool pump or fan only	1. The setting of thermal overload relay is too low. 2. Thermal overload relay signal failure 3. Thermal overload relay damaged 4." Cool overload" setting is not right	1. Start chiller to see if the fans current is normal, if it is normal, adjusting the current setting appropriately. 2. Check if the signal line is virtual open or not 3. Replace the thermal overload relay 4. Check the settings
Cool.I high	The current of cool pump or Fan is too high			Check if the rated current of cool is input is reasonable.	
Cool.I low	The current of cool pump or Fan is too low			Check if the measure tool of the cool current is connect.	
Cool W.flow AL	Lack of cool water flow	Test after the cool pump starts for [Cool on delay] time	Stop compressor and cool pump or fan only		Check if the cool water flow input is consistent with the switch setting.

Cold W.flow AL	Lack of cold water flow	Test after the cold pump starts for [Pump on delay] time	If the [Lack of liquid] is set “Pump keep”, Stop compressor and cool pump in case of fault. If the [Lack of liquid] is set “Pump stop”, Stop the unit in case of fault.	1. Chilled water flow rate is too low or water shortage or water flow switch setting rate too high. 2. Water flow switch damaged 3. Cold pump overload 4. Water flow switch signal line fault 5. “Cold W. flow” setting is not right	1. Check the water tank or pipe whether there is sufficient water, such as water shortage, add water to the tank. If the water flow is sufficient, check and readjust the flow switch, details see “ Water flow switch failure ” 2. Replace the water flow switch 3. See “ Cold pump Overload ” 4. Check if the signal line is virtual open or not 5. Check the settings Note: When the pump is not control by chiller, Please set the “Flow Switch” for NO to prevent alarm
cold pump overload [Note3]	The cold pump overload	Test after cold pump starts	Stop the unit	1. Cold pump current too high 2. Chilled pump’s signal line fault 3. Thermal overload relay damaged 4. “Freez overload” setting is not right	1. Check whether the thermal overload relay is trip out. If so, reset it and start the chiller to check whether the pump current is normal or not. If normal, adjust the thermal overload relay setting current. 2. Check if the signal line is virtual open or not. 3. Replace thermal overload relay 4. Check the settings
Pump.I high	The current of cold pump is too high				Check if the rated current of cold is input is reasonable.
Pump.I low	The current of cold pump is too low				Check if the measure tool of the cold current is connect.
Phase AL	The three-phase power input is alarm	Power on to test	Stop the unit	1. Phase loss 2. Phase sequence errors 3. Overhigh voltage 4. Undervoltage 5. Voltage unbalance 6. Wiring fault 7. Phase sequence is damaged 8. “Phase Swtich” setting is not right	1-7 Check the Voltage size and volatility between two-phase. If all is normal, check the wiring of the phase sequence (Including three-phase power input and the line of output). If it’s damaged, change a new one. 8. Check the settings
Water level AL	The water level is low	Power on to test	If the [Low liquid lv] is	1. Chilled water level rate is too low	1. Add water to the tank until the water level is

			set “Pump keep”, Stop compressor and cool pump in case of fault. If the [Low liquid lv] is set “Pump stop”, Stop the unit in case of fault.	or water shortage. 2. Water level switch damaged 3. Water level switch signal line fault 4. “W.level switch” setting is not right	normal 2. Replace the water level switch 3. Check if the signal line is virtual open or not 4. Check the settings Note: When the pump is not control by chiller, Please set the “Level Swtich” for NO to prevent alarm
Need Maintenance	The total time of compressor run over the allow value	Test after cold pump starts			The unit cannot start once stops (the accumulative operation time of compressor exceeds the set value).

[Note 1]: In case of "1#Comp.P low " fault, if [LP stop pump] is not zero, the troubleshooting program is: to immediately stop all compressors and cool pump, delay the [LP stop pump] and stop the cold pump. If [LP stop pump] is zero, then the troubleshooting program is: to only stop compressor1 without affect other equipments to work.

[Note 2]: In case of "2#Comp.P low " fault, if [LP stop pump] is not zero, the troubleshooting program is: to immediately stop all compressors and cool pump, delay the [LP stop pump] and stop the cold pump. If [LP stop pump] is zero, then the troubleshooting program is: to only stop compressor2 without affect other equipments to work.

[Note3]:

Machine type	Cold Pump Overld	Cool Pump Overld
fan-cooled water chiller	Cold Pump Overld	Cool Fan Overld
water-cooled water chiller	Cold Pump Overld	Cool Pump Overld
fan-cooled fan cooler	Cold Fan Overld	Cool Fan Overld
water-cooled fan cooler	Cold Fan Overld	Cool Pump Overld

7.2 Hardware faults

Fault phenomenon	Reason	Troubleshooting
The power supply has power, and the switch is closed, but the controller does not respond	1.The control transformer is damaged 2.The controller is damaged 3.The breaker is damaged 4.The control line failure	1.Check the voltage across the transformer 2.Replace the controller 3.Replace the breaker 4.Check the control line

<p>The controller has pump running output signal, but the pump did not start for a long time without faults</p>	<ol style="list-style-type: none"> 1. The contactor is damaged 2. The control line failure 3. The controller's output is damaged 4. The pump power line failure 5. The pump is damaged 	<p>1. Step: Check three-phase voltage of pump → Check contactor → Check controller's output</p> <p>2. If checking pump has three-phase voltage, indicating that the pump has been damaged. If there is no voltage, check that if the contactor is pull or not;</p> <p>3. If the contactor is pull, indicating that the main contact of the contactor is disconnected, you need replace a contactor. If not pull, check that if the contactor coil voltage is 220V or not;</p> <p>4. If the contactor coil voltage is 220V, indicating that the contactor has been damaged. If no voltage, check that if the controller's output voltage is 220V or not;</p> <p>5. If the controller's output voltage is 220, indicating that the control line is disconnected. If no voltage, indicating that the controller's output has been damaged. You need repair controller or replace a new controller</p>
<p>The controller has compressor running output signal, but the compressor did not start for a long time without faults</p>	<ol style="list-style-type: none"> 1. The contactor is damaged 2. The control line failure 3. The controller's output is damaged 4. The compressor power line failure 5. The compressor is damaged 	<p>The same as above</p>
<p>The controller has heating running output signal, but the heater did not start for a long time without faults</p>	<ol style="list-style-type: none"> 1. The contactor is damaged 2. The control line failure 3. The controller's output is damaged 4. The heater power line failure 5. The heater is damaged 	<p>The same as above</p>
<p>The compressor is running, but the fans or cooling pump did not start for a long time without faults</p>	<ol style="list-style-type: none"> 1. The contactor is damaged 2. The control line failure 3. The controller's output is damaged 4. The fans or cooling pump power line failure 5. The fans or cooling pump is damaged 	<p>The same as above</p>
<p>The pump or fan or compressor displays overload alarm or stopped on the controller, but it's still running, not stopped</p>	<ol style="list-style-type: none"> 1. Contactor stuck 2. Control line error connection 3. Controller logic program error 	<p>1. Step: Contactor → Control line → Controller</p> <p>2. Turn off the main power, turn on the electric box and observe the contactor. If the contactor stuck, it is not automatically rebound without power, then you must replace the new contactor. Otherwise, it is easy to burn out the motor.</p> <p>3. If the contactor is automatically rebound, indicating that the contactor is good. Then check that if the control line is connecting right or not;</p> <p>4. If the control line is connecting error, the control</p>

		<p>sequence is bound to be confused. Please check the sequence according to the control logic, and correct the control line. If the control line is connecting right, check that if the controller logic program is right or not;</p> <p>5. If the controller logic program is error, then you must replace the new controller.</p>
Button operation is unresponsive	<ol style="list-style-type: none"> 1. Button is damaged 2. Button line error connection 3. Controller inputs is damaged 4. Controller crash 	<ol style="list-style-type: none"> 1. Replace new button 2. Check button line 3. Repair controller or replace a new controller 4. Restart, The chiller must be grounded.
The power supply is on, but the power indicator is not on	<ol style="list-style-type: none"> 1. The power indicator is damaged 2. Power indicator line error connection 	<ol style="list-style-type: none"> 1. Replace a new power indicator 2. Check indicator line
The chiller is running, but the run indicator is not on	<ol style="list-style-type: none"> 1. The run indicator is damaged 2. Run indicator line error connection 	<ol style="list-style-type: none"> 1. Replace a new run indicator 2. Check indicator line
The chiller alarm, but the alarm indicator is not on	<ol style="list-style-type: none"> 1. The alarm indicator is damaged 2. Alarm indicator line error connection 	<ol style="list-style-type: none"> 1. Replace a new alarm indicator 2. Check indicator line

8.1. 电路图/ Wiring diagram

HC-W 380V 动力电路/Power circuit

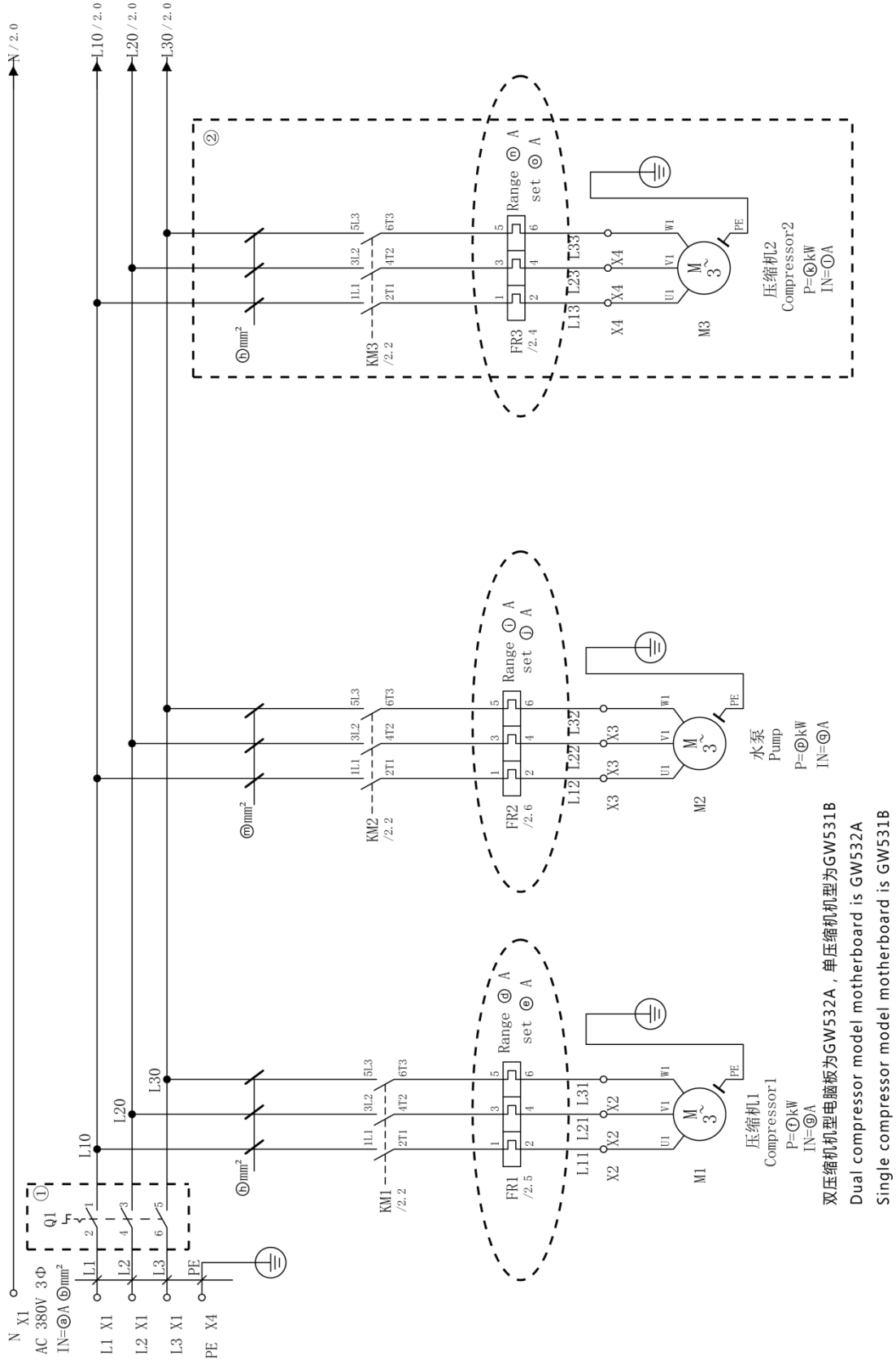

双压缩机机型电脑板为GW532A，单压缩机机型为GW531B
 Dual compressor model motherboard is GW532A
 Single compressor model motherboard is GW531B

HC-W 380V 控制电路/Control circuit

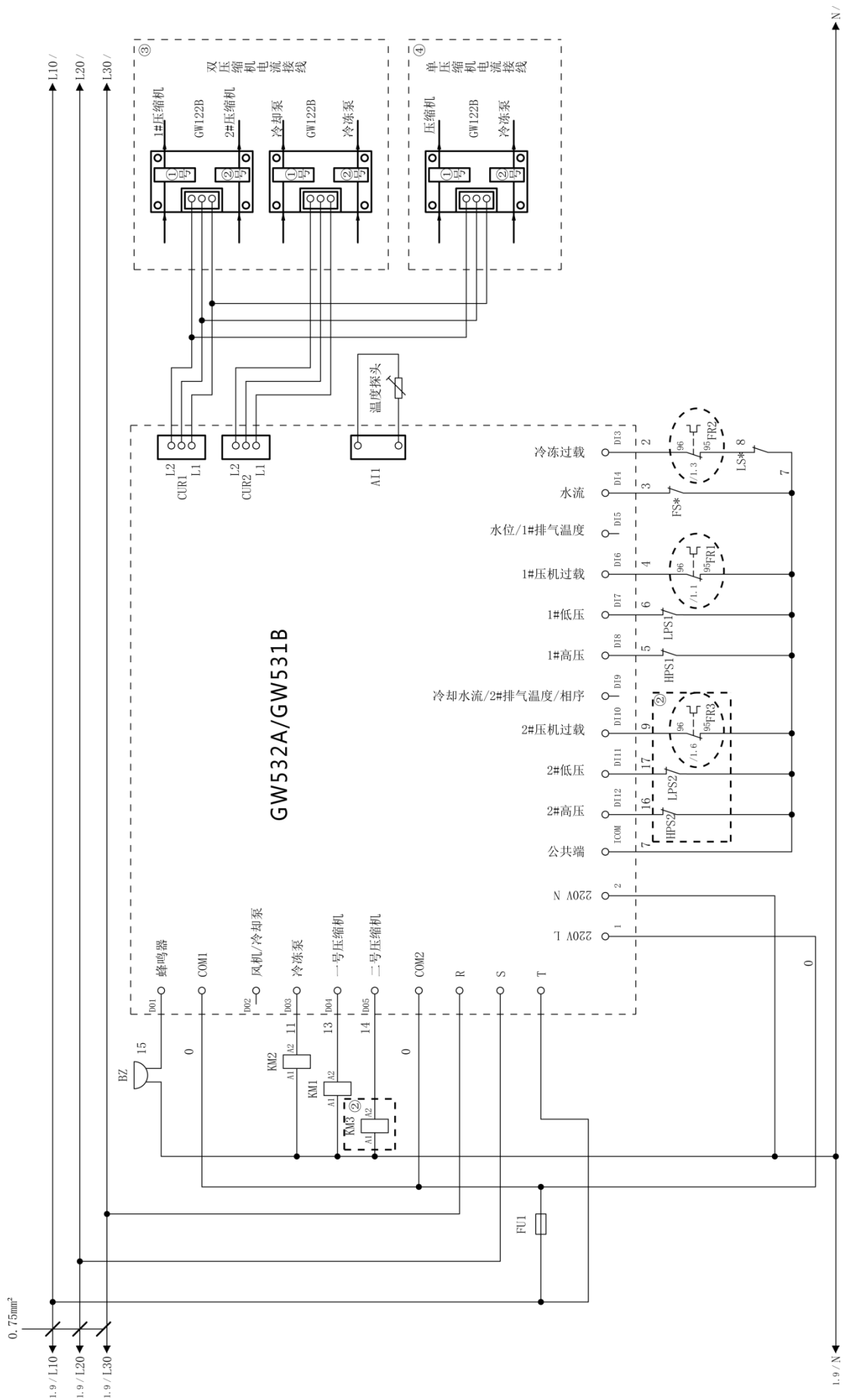

HC-A 380V 动力电路/Power circuit

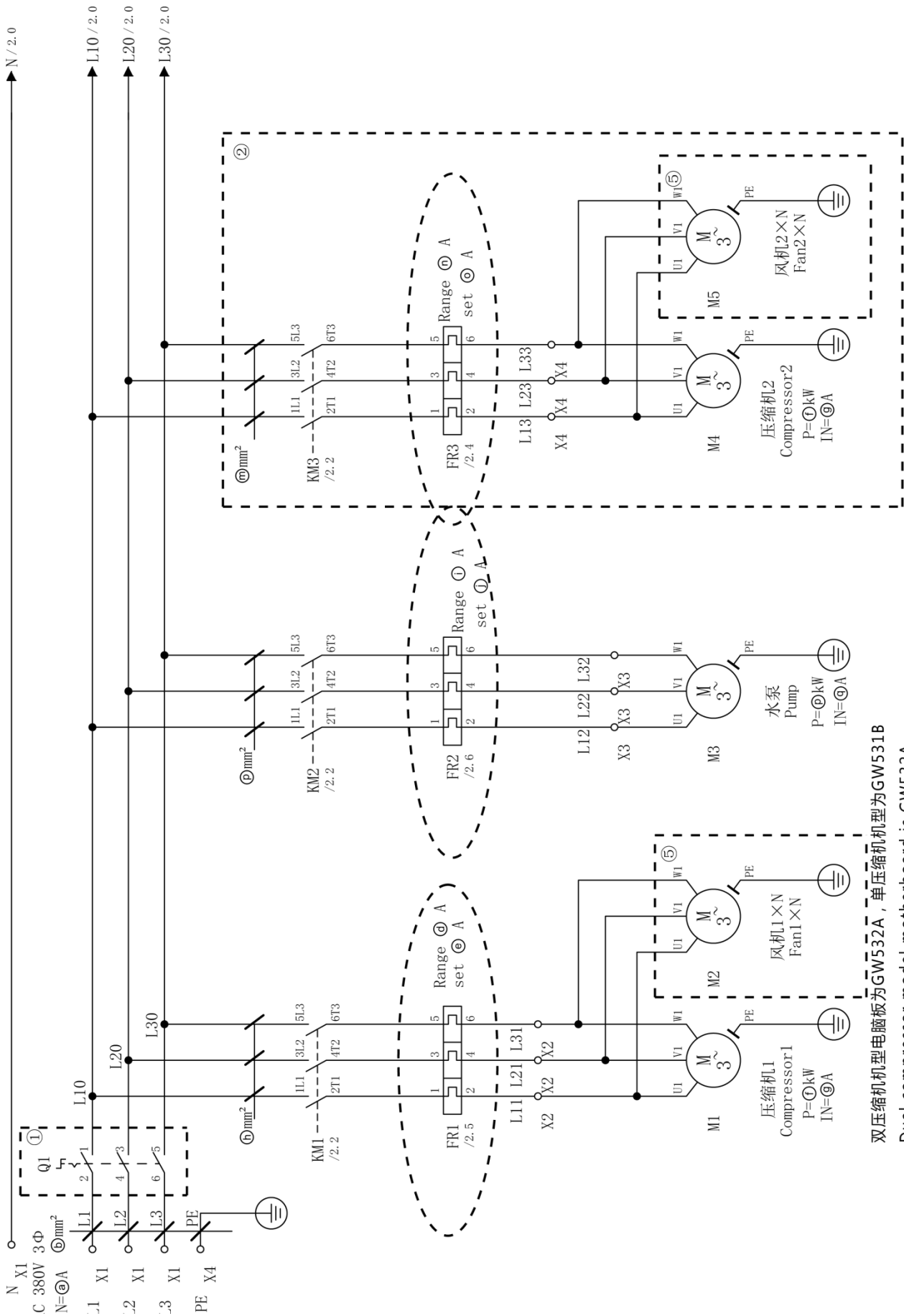

双压缩机电脑板为GW532A，单压缩机机型为GW531B
 Dual compressor model motherboard is GW532A
 Single compressor model motherboard is GW531B

HC-A 380V 控制电路/Control circuit

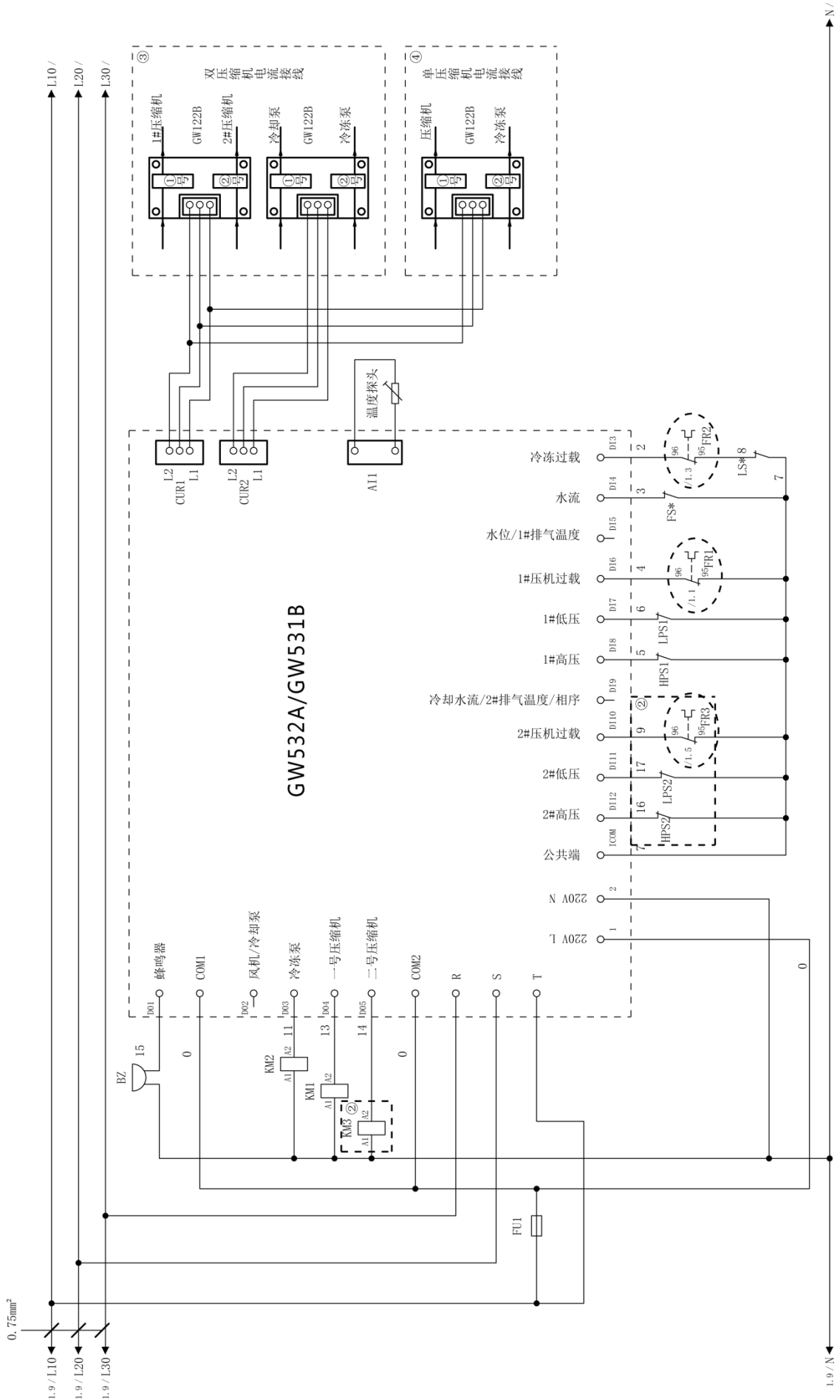

HC-W 220V 动力电路/Power circuit

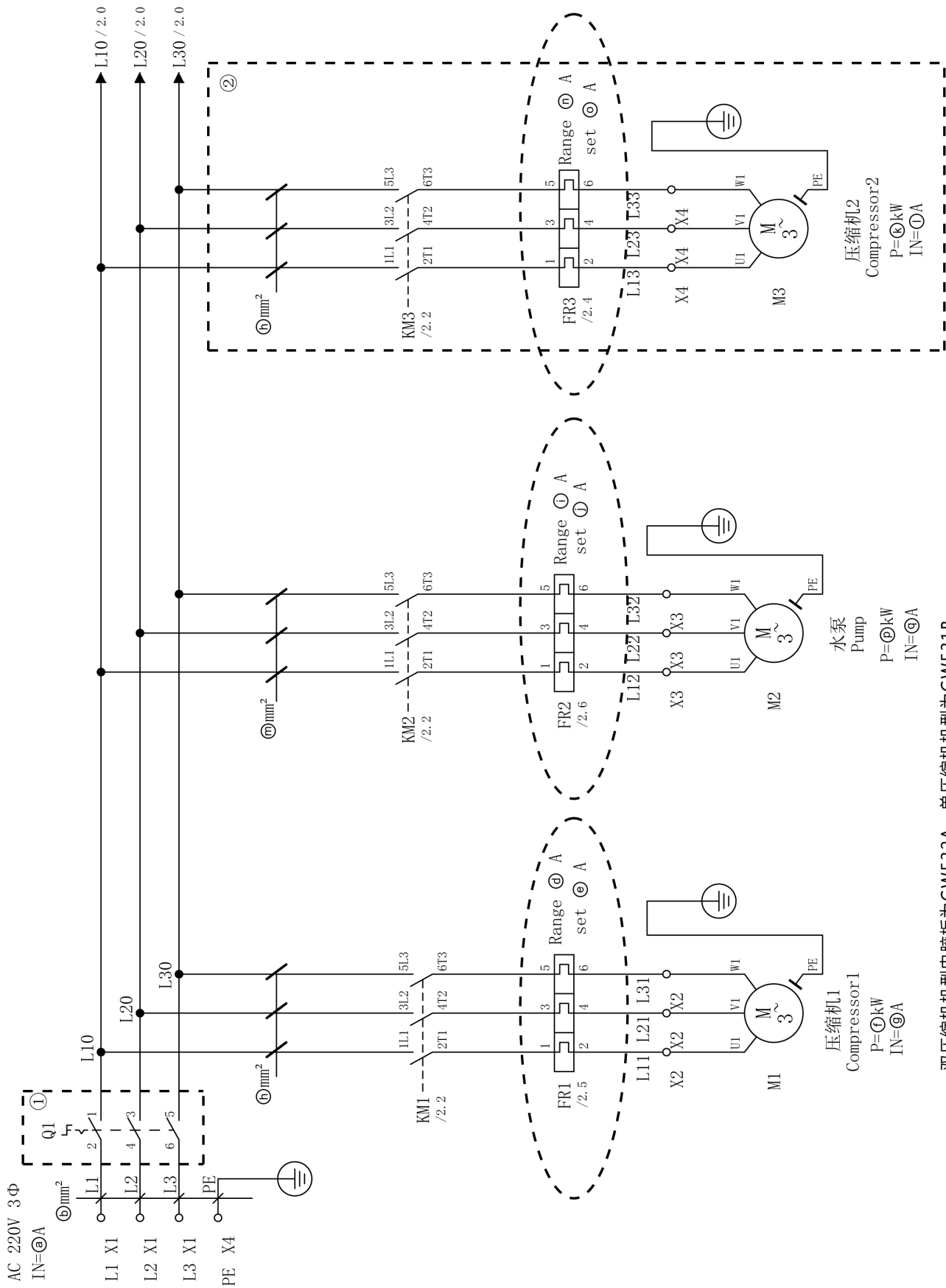

双压缩机电脑板为GW532A，单压缩机机型为GW531B

Dual compressor model motherboard is GW532A

Single compressor model motherboard is GW531B

HC-W 220V 控制电路/Control circuit

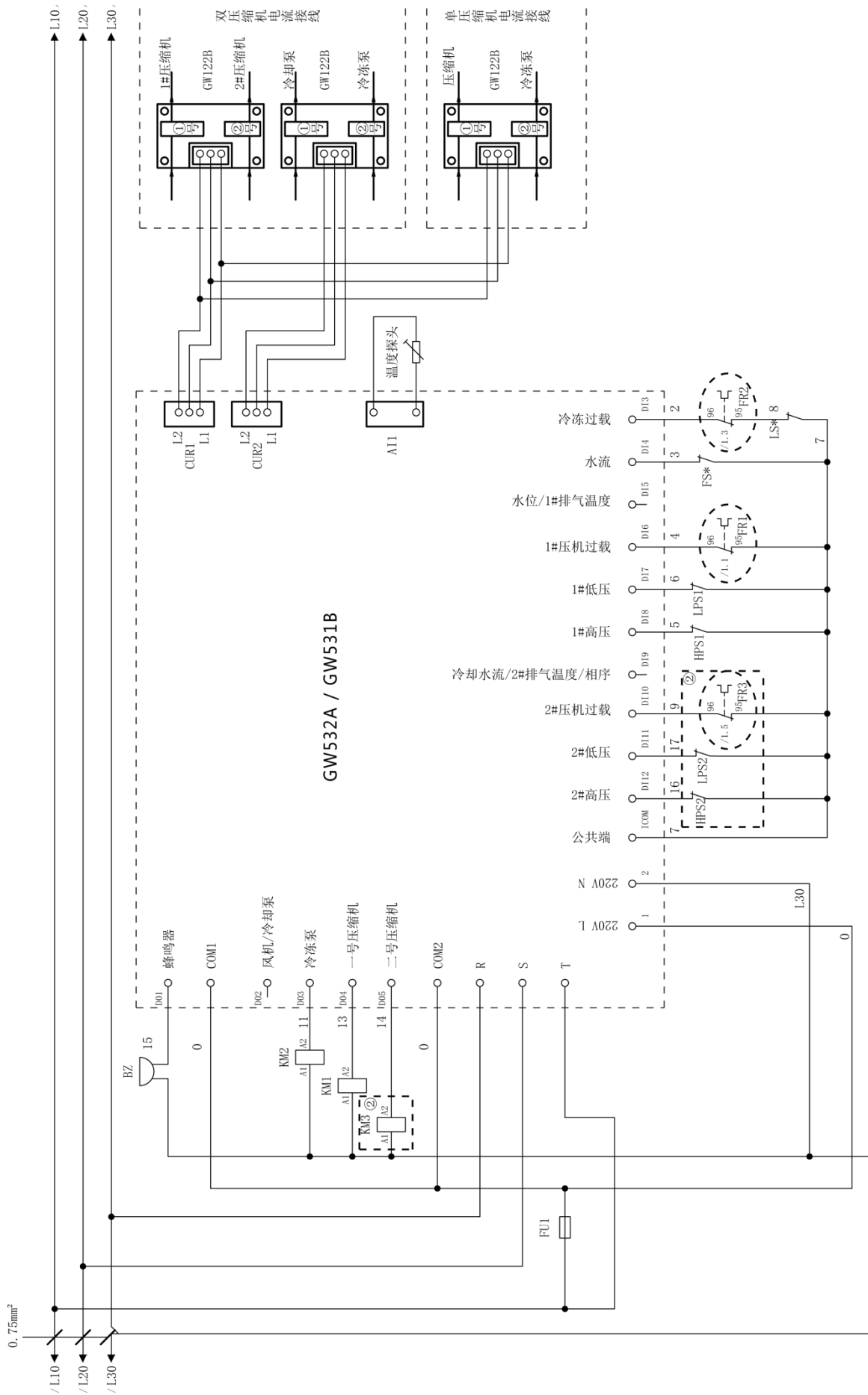

HC-A 220V 动力电路/Power circuit

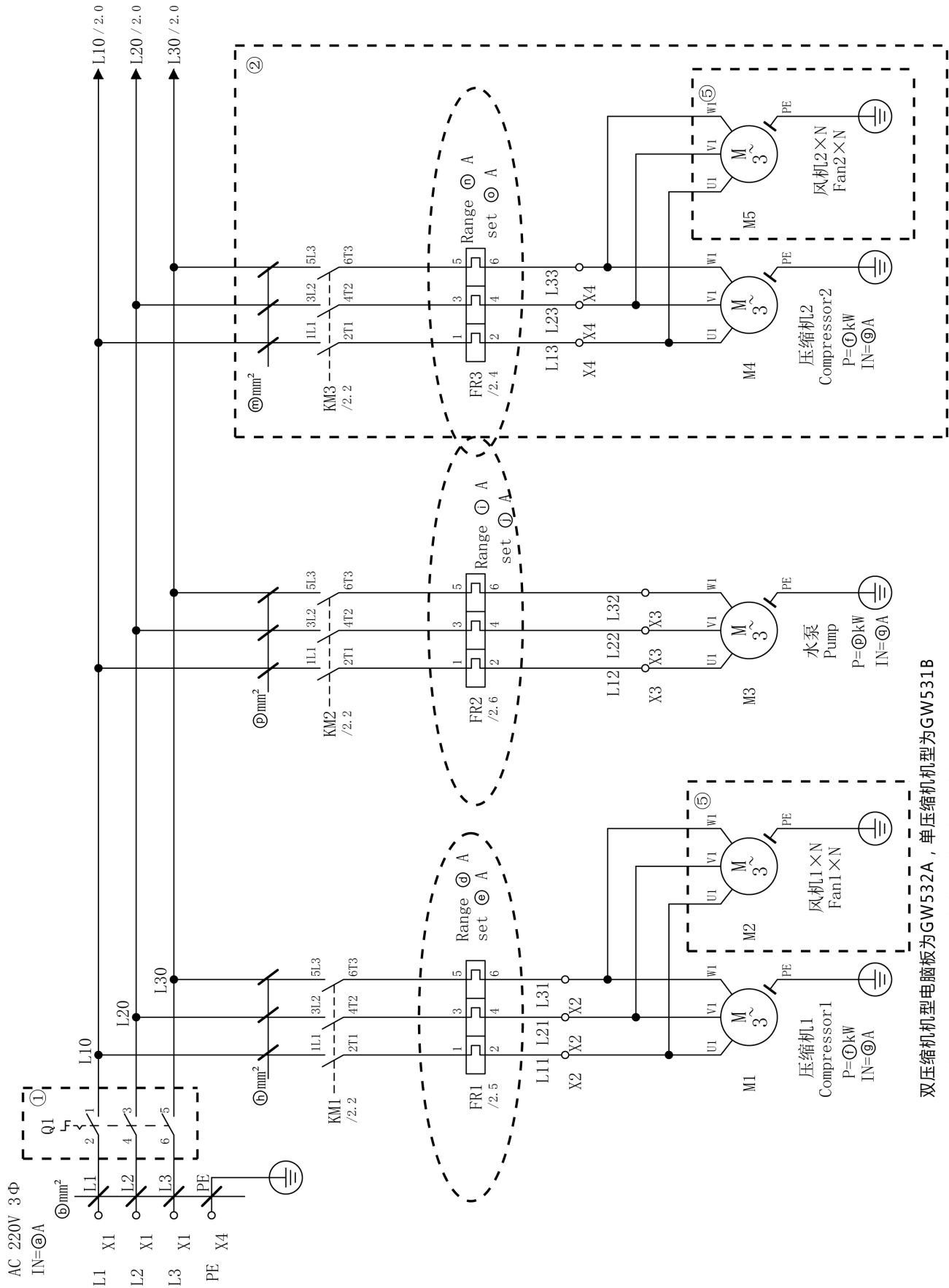

双压缩机电脑板为GW532A，单压缩机机型为GW531B

Dual compressor model motherboard is GW532A

Single compressor model motherboard is GW531B

HC-A 220V 控制电路/Control circuit

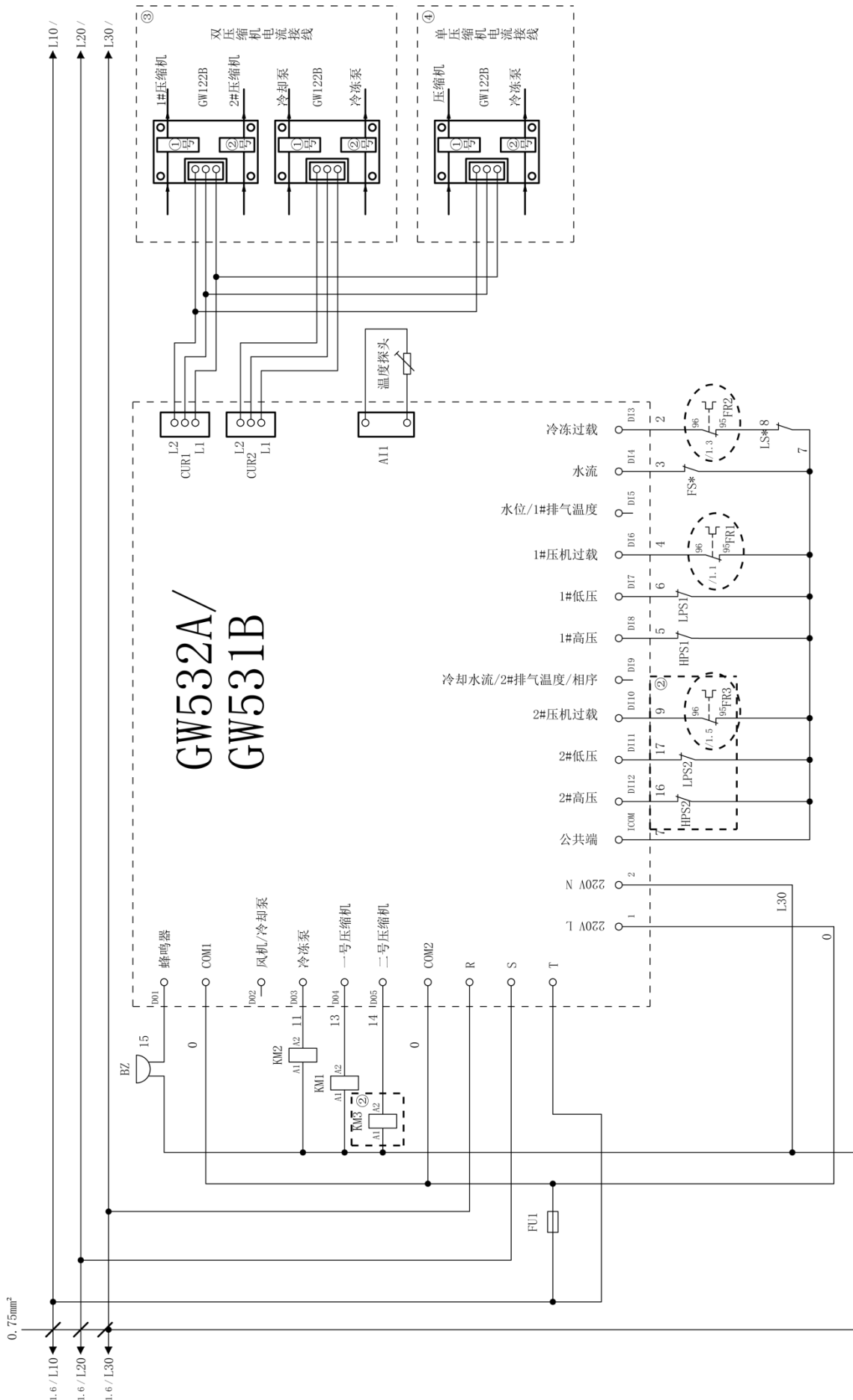

8.2. 电气元件/Electrical components

HC-03W ~HC-50W (380V 50Hz)

No	代码 CODE	物料名称 MATERIAL NAME	HC-03W	HC-05W	HC-08W	HC-10W	HC-12W	HC-15W
1	KM1	交流接触器 A.C. Contractor	220VAC 0910	220VAC 1210	220VAC 1810	220VAC 2510	220VAC 3210	220VAC 3810
2	KM2	交流接触器 A.C. Contractor	220VAC 0610	220VAC 0610	220VAC 0610	220VAC 0610	220VAC 0610	220VAC 0910
3	FR1 FR2	电子互感器 Electronic transformer	GW122B	GW122B	GW122B	GW122B	GW122B	GW122B
4	M1	压缩机 Compressor	380V 50Hz 3HP	380V 50Hz 5HP	380V 50Hz 8HP	380V 50Hz 10HP	380V 50Hz 12HP	380V 50Hz 15HP
5	M2	泵 pump	380VAC 0.75kW	380VAC 0.75kW	380VAC 1.5kW	380VAC 1.5kW	380VAC 1.5kW	380VAC 3kW

No	代码 CODE	物料名称 MATERIAL NAME	HC-20W-D	HC-25W-D	HC-30W-D	HC-40W-D	HC-50W-D
1	KM1	交流接触器 A.C. Contractor	220VAC 2510	220VAC 2510	220VAC 3810	220VAC 50M7	220VAC 50M7
2	KM2	交流接触器 A.C. Contractor	220VAC 0910	220VAC 0910	220VAC 1210	220VAC 1810	220VAC 1810
	KM3	交流接触器 A.C. Contractor	220VAC 2510	220VAC 2510	220VAC 3810	220VAC 50M7	220VAC 50M7
3	FR1 FR2	电子互感器 Electronic transformer	2- GW122B	2- GW122B	2- GW122B	2- GW122B	2- GW122B
4	M1	压缩机 Compressor	2- 380V 50Hz 10HP	2- 380V 50Hz 10HP	2- 380V 50Hz 15HP	2- 380V 50Hz 20HP	2- 380V 50Hz 25HP
5	M2	泵 pump	380VAC 3kW	380VAC 3kW	380VAC 4kW	380VAC 5.5kW	380VAC 5.5kW

HC-03A ~HC-50A (380V 50Hz)

No	代码 CODE	物料名称 MATERIAL NAME	HC-03A	HC-05A	HC-08A	HC-10A	HC-12A	HC-15A
1	KM1	交流接触器 A.C. Contractor	220VAC 0910	220VAC 1210	220VAC 1810	220VAC 2510	220VAC 3210	220VAC 3810
2	KM2	交流接触器 A.C. Contractor	220VAC 0610	220VAC 0610	220VAC 0610	220VAC 0610	220VAC 0610	220VAC 0910
3	FR1 FR2	电子互感器 Electronic transformer	GW122B	GW122B	GW122B	GW122B	GW122B	GW122B
4	M1	压缩机 Compressor	380V 50Hz 3HP	380V 50Hz 5HP	380V 50Hz 8HP	380V 50Hz 10HP	380V 50Hz 12HP	380V 50Hz 15HP
5	M2	泵 pump	380VAC 0.75kW	380VAC 0.75kW	380VAC 1.5kW	380VAC 1.5kW	380VAC 1.5kW	380VAC 3kW

N o	代码 CODE	物料名称 MATERIAL NAME	HC-20A-D	HC-25A-D	HC-30A-D	HC-40A-D	HC-50A-D
1	KM1	交流接触器 A.C. Contractor	220VAC 2510	220VAC 2510	220VAC 3810	220VAC 50M7	220VAC 50M7
2	KM2	交流接触器 A.C. Contractor	220VAC 0910	220VAC 0910	220VAC 1210	220VAC 1810	220VAC 1810
	KM3	交流接触器 A.C. Contractor	220VAC 2510	220VAC 2510	220VAC 3810	220VAC 50M7	220VAC 50M7
3	FR1 FR2	电子互感器 Electronic transformer	2- GW122B	2- GW122B	2- GW122B	2- GW122B	2- GW122B
4	M1	压缩机 Compressor	2- 380V 50Hz 10HP	2- 380V 50Hz 10HP	2- 380V 50Hz 15HP	2- 380V 50Hz 20HP	2- 380V 50Hz 25HP
5	M2	泵 pump	380VAC 3kW	380VAC 3kW	380VAC 4kW	380VAC 5.5kW	380VAC 5.5kW

HC-03W ~HC-50W (380V 50Hz)

HC-03A ~HC-50A (380V 50Hz)

No	代码 CODE	物料名称 MATERIAL NAME	HC-03W	HC-05W	HC-08W	HC-10W	HC-12W	HC-15W
1	GW	电脑板 Motherboard	GW531B	GW531B	GW531B	GW531B	GW531B	GW531B
2	FU1	保险管 FUUSE	220VAC 2A	220VAC 2A	220VAC 2A	220VAC 2A	220VAC 2A	220VAC 2A
3	BZ	蜂鸣器 Buzzer	220VAC AD17	220VAC AD17	220VAC AD17	220VAC AD17	220VAC AD17	220VAC AD17
4	HPS LPS	压控开关 Pressure Switch	P830E	P830E	P830E	P830E	P830E	P830E
5	CUR	电子互感器 Electronic transformer	GW122B	GW122B	GW122B	GW122B	GW122B	GW122B

N o	代码 CODE	物料名称 MATERIAL NAME	HC-20W-D	HC-25W-D	HC-30W-D	HC-40W-D	HC-50W-D
1	GW	电脑板 Motherboard	GW531B	GW531B	GW531B	GW531B	GW531B
2	FU1	保险管 FUUSE	220VAC 2A	220VAC 2A	220VAC 2A	220VAC 2A	220VAC 2A
3	BZ	蜂鸣器 Buzzer	220VAC AD17	220VAC AD17	220VAC AD17	220VAC AD17	220VAC AD17
4	HPS LPS	压控开关 Pressure Switch	P830E	P830E	P830E	P830E	P830E
5	CUR	电子互感器 Electronic transformer	GW122B	GW122B	GW122B	GW122B	GW122B

9. 部件名称/PARTS LIST

HC-ACI

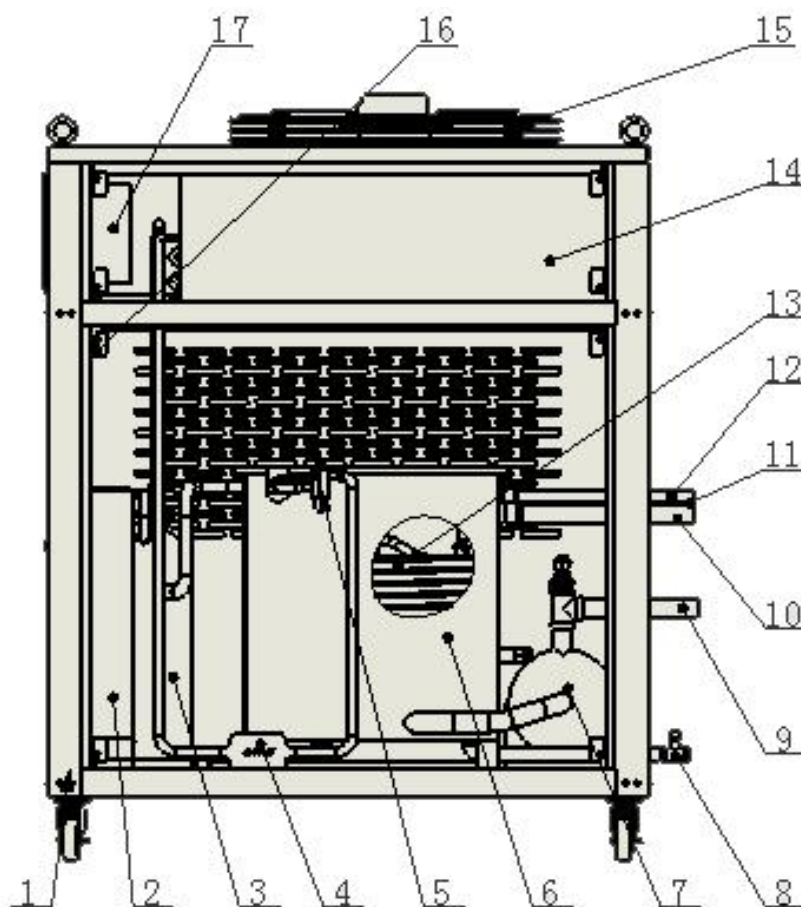

ITEM	物料名称 MATERIAL NAME	备注
1	钣金架体 Sheet metal frame	
2	电箱组件 Electrical box	
3	压缩机 Compressor	
4	干燥过滤器 Dry filter	
5	膨胀阀 Expansion valve	
6	水箱组件 Tank assembly	
7	水泵 Water pump	
8	排污管 Sewer pipe	
9	冷冻水出管 Chilled water outlet	
10	溢水管 Spill pipe	
11	冷冻水回管 Chilled water inlet	
12	加水管 Add water pipe	
13	蒸发器 Evaporator	盘管/Coil
14	冷凝器 Condenser	翅片/Fin
15	风机 Fan	
16	压力开关 Pressure Switch	
17	电脑板 Motherboard	

HC-WCI

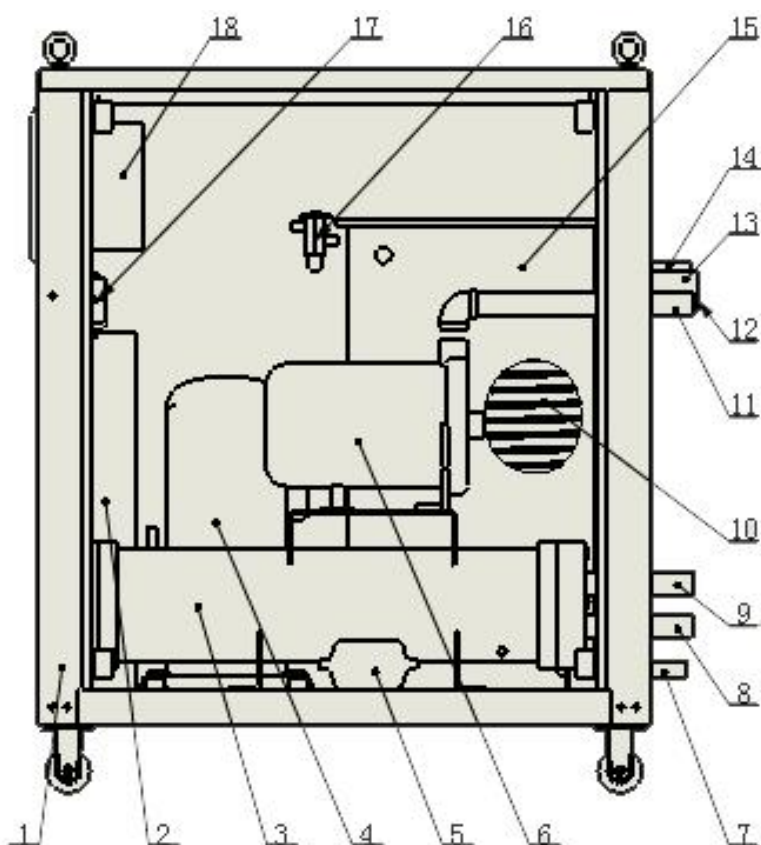

ITEM	物料名称 MATERIAL NAME	备注
1	钣金架体 Sheet metal frame	
2	电箱组件 Electrical box	
3	冷凝器 Condenser	壳管/Shell
4	压缩机 Compressor	
5	干燥过滤器 Dry filter	
6	水泵 Water pump	
7	排污管 Sewer pipe	
8	冷却水进口 Cooling water inlet	
9	冷却水出口 Cooling water outlet	
10	蒸发器 Evaporator	盘管/Coil
11	冷冻水出管 Chilled water outlet	
12	溢水管 Spill pipe	
13	冷冻水回管 Chilled water inlet	
14	加水管 Add water pipe	
15	水箱组件 Tank assembly	
16	膨胀阀 Expansion valve	
17	压力开关 Pressure Switch	
18	电脑板 Motherboard	

HC-SACI

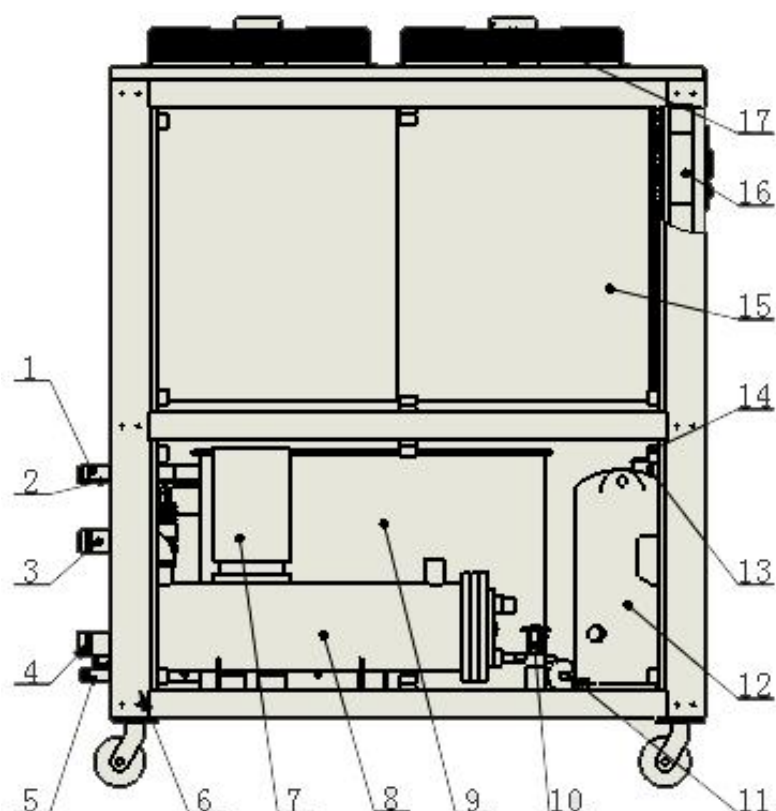

ITEM	物料名称 MATERIAL NAME	备注
1	加水管 Add water pipe	
2	溢水管 Spill pipe	
3	冷冻水回管 Chilled water inlet	
4	冷冻水出管 Chilled water outlet	
5	排污管 Sewer pipe	
6	钣金架体 Sheet metal frame	
7	水泵 Water pump	
8	蒸发器 Evaporator	壳管/Shell
9	水箱组件 Tank assembly	
10	膨胀阀 Expansion valve	
11	干燥过滤器 Dry filter	
12	压缩机 Compressor	
13	电箱组件 Electrical box	
14	压力开关 Pressure Switch	
15	冷凝器 Condenser	翅片/Fin
16	电脑板 Motherboard	
17	风机 Fan	

HC-SWCI

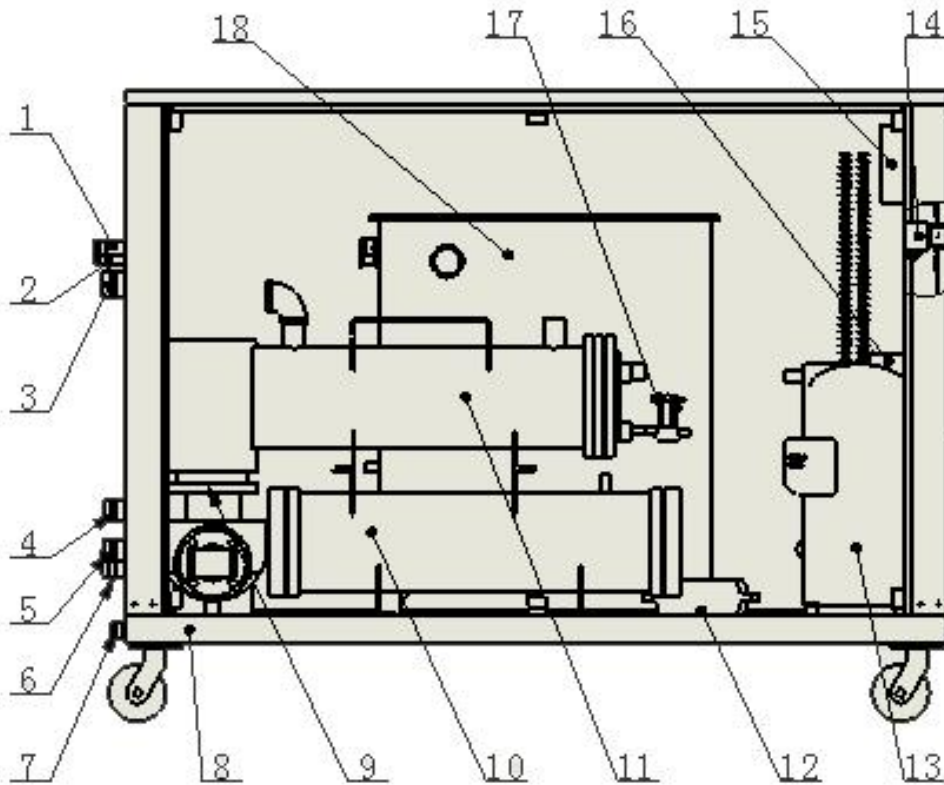

ITEM	物料名称 MATERIAL NAME	备注
1	加水管 Add water pipe	
2	溢水管 Spill pipe	
3	冷冻水回管 Chilled water inlet	
4	冷却水出口 Cooling water outlet	
5	冷却水进口 Cooling water inlet	
6	冷冻水出管 Chilled water outlet	
7	排污管 Sewer pipe	
8	钣金架体 Sheet metal frame	
9	水泵 Water pump	
10	冷凝器 Condenser	壳管/Shell
11	蒸发器 Evaporator	壳管/Shell
12	干燥过滤器 Dry filter	
13	压缩机 Compressor	
14	压力开关 Pressure Switch	
15	电脑板 Motherboard	
16	电箱组件 Electrical box	
17	膨胀阀 Expansion valve	
18	水箱组件 Tank assembly	